

BEAGLE

Berkeley SoC Components in Intel 22FFL

Abraham Gonzalez, and many more
abe.gonzalez@berkeley.edu

Berkeley
UNIVERSITY OF CALIFORNIA



**Berkeley
Architecture
Research**





A Perfect Storm...

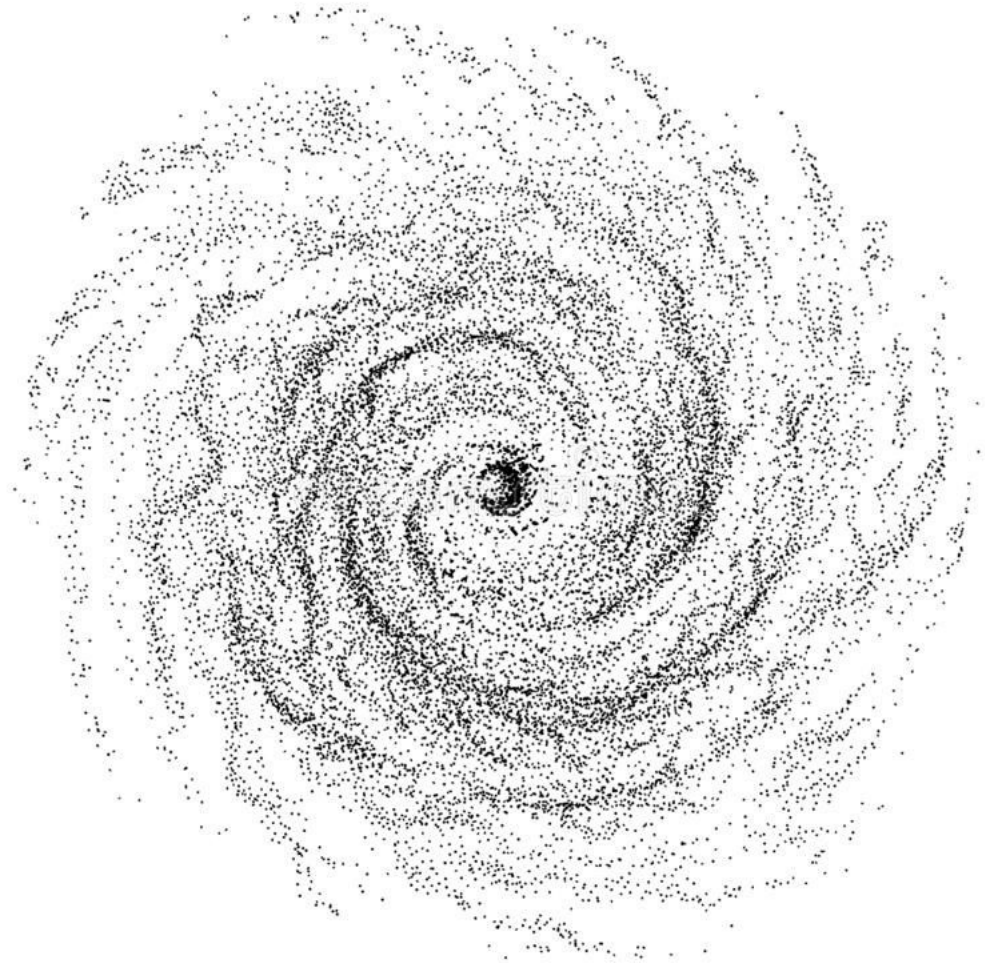



A Perfect Storm...

“Cold Air”

Older graduate students and prior BOOM developers who have intimate tapeout knowledge are leaving.

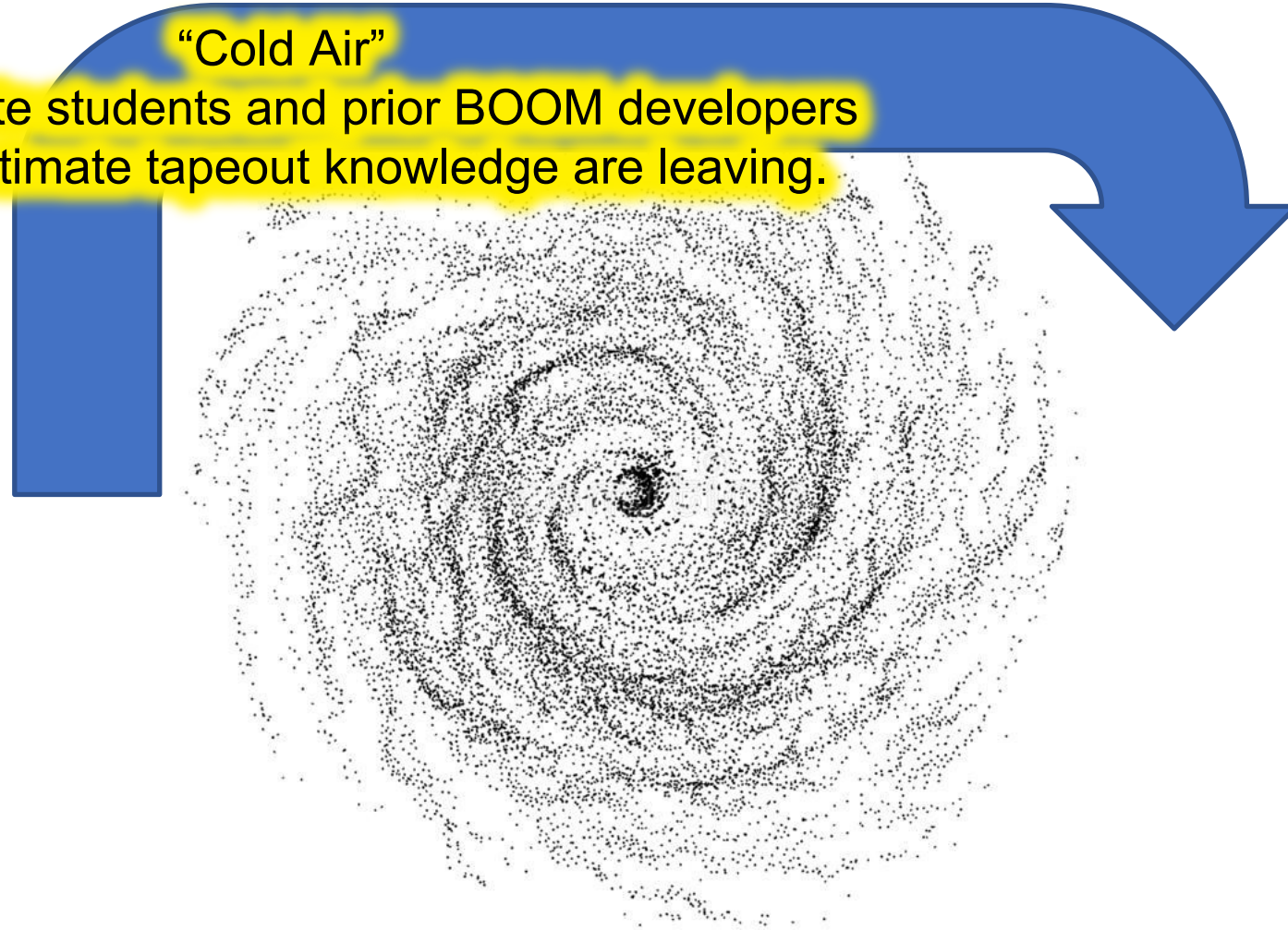



A Perfect Storm...

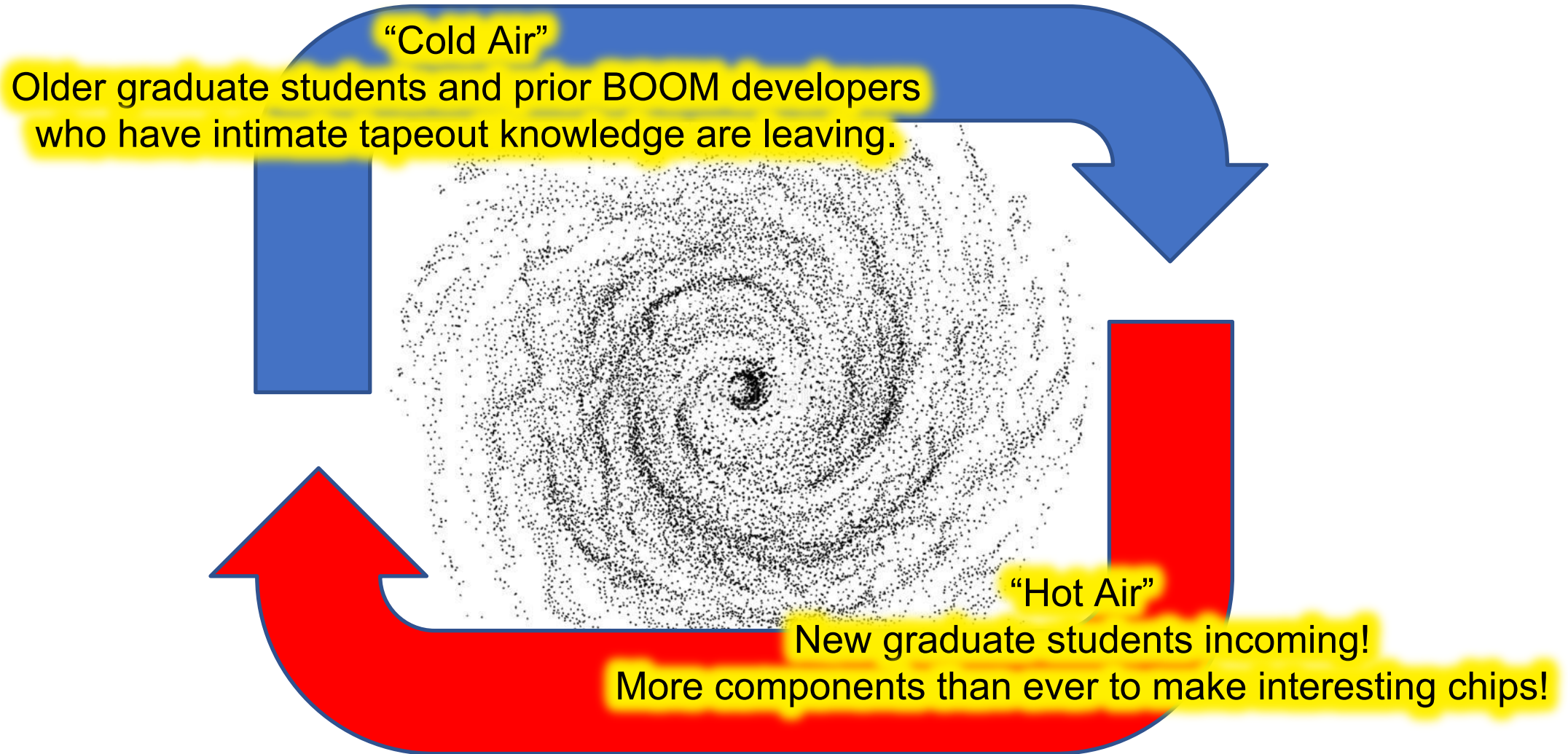



A Perfect Storm...

“Cold Air”

Older graduate students and prior BOOM developers who have intimate tapeout knowledge are leaving.

BEAGLE = BOOM + EAGLE



“Hot Air”

New graduate students incoming!
More components than ever to make interesting chips!



A BEAGLE is born

Goals

- Tapeout Intel 22FFL
- Second BOOM chip
 - Updated BOOMv2.2 core
 - Done with a completely new team
 - Jerry Z., Ben K., and more
- Create first multi-core heterogeneous system with Chipyard-like ecosystem
 - BOOM + Rocket
 - Gemmini + Hwacha
 - L2 + Serial Links + IOs

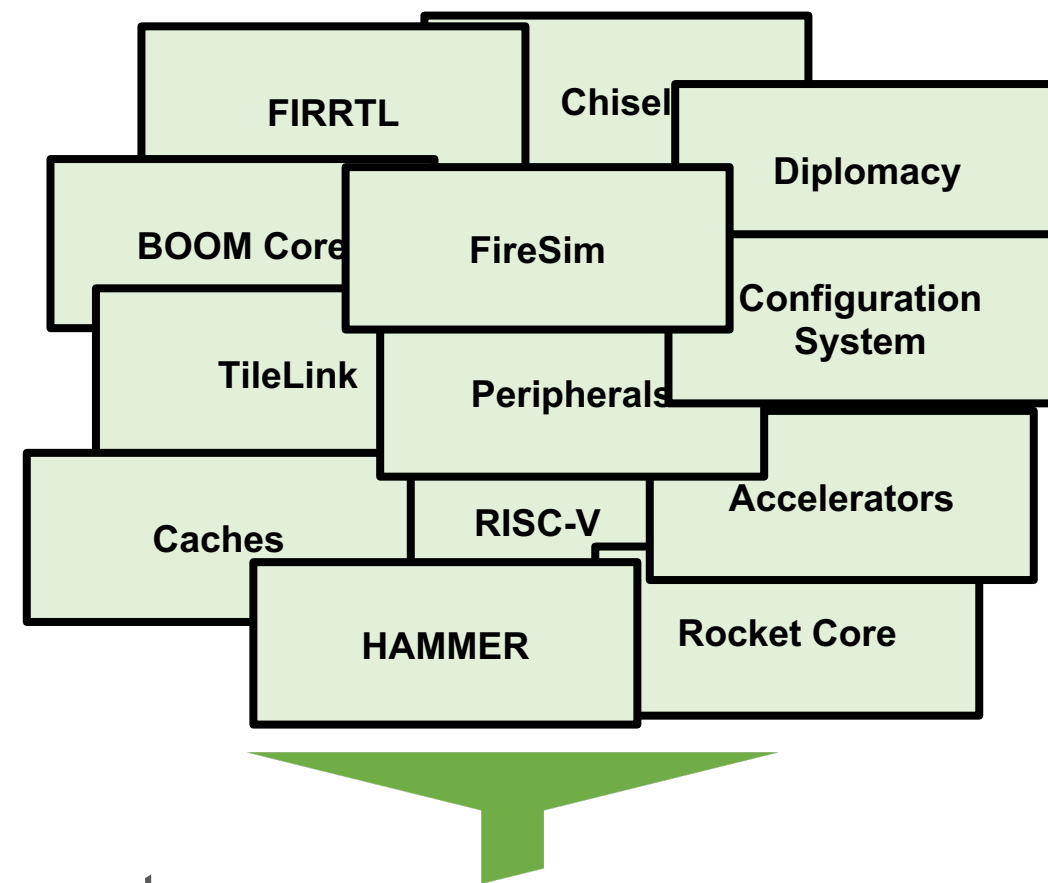



BEAGLE Block Diagram

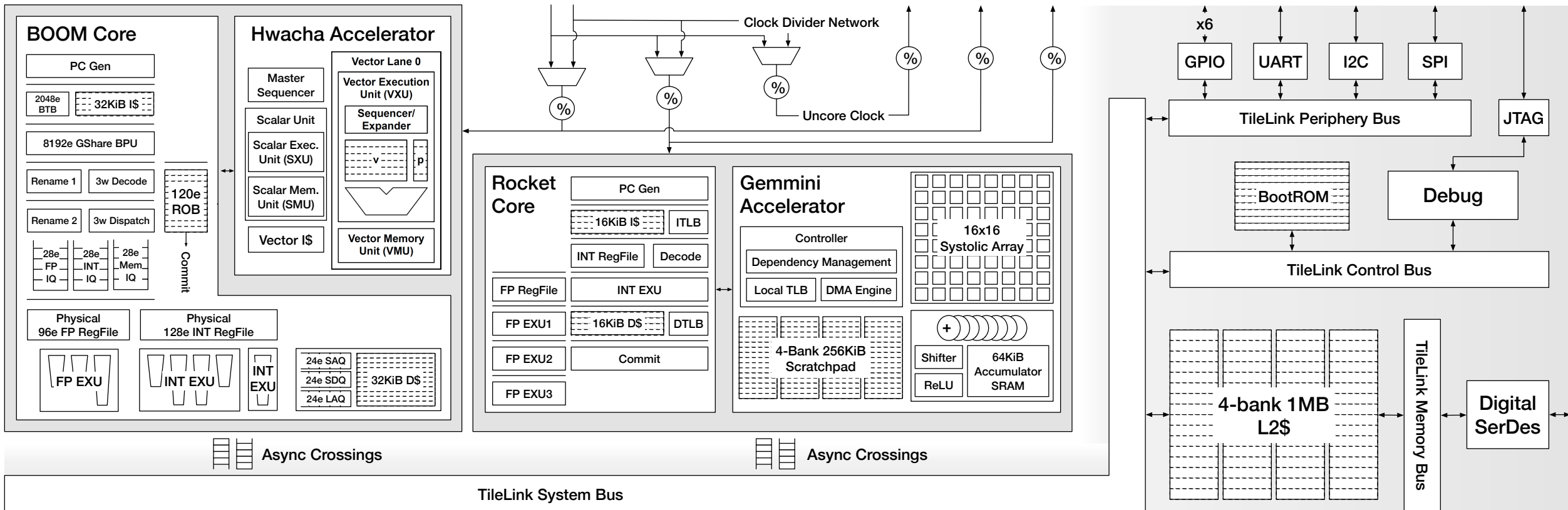

- Two compute domains and uncore
 - Each with separate asynchronous clock/power domains



General Application Domain

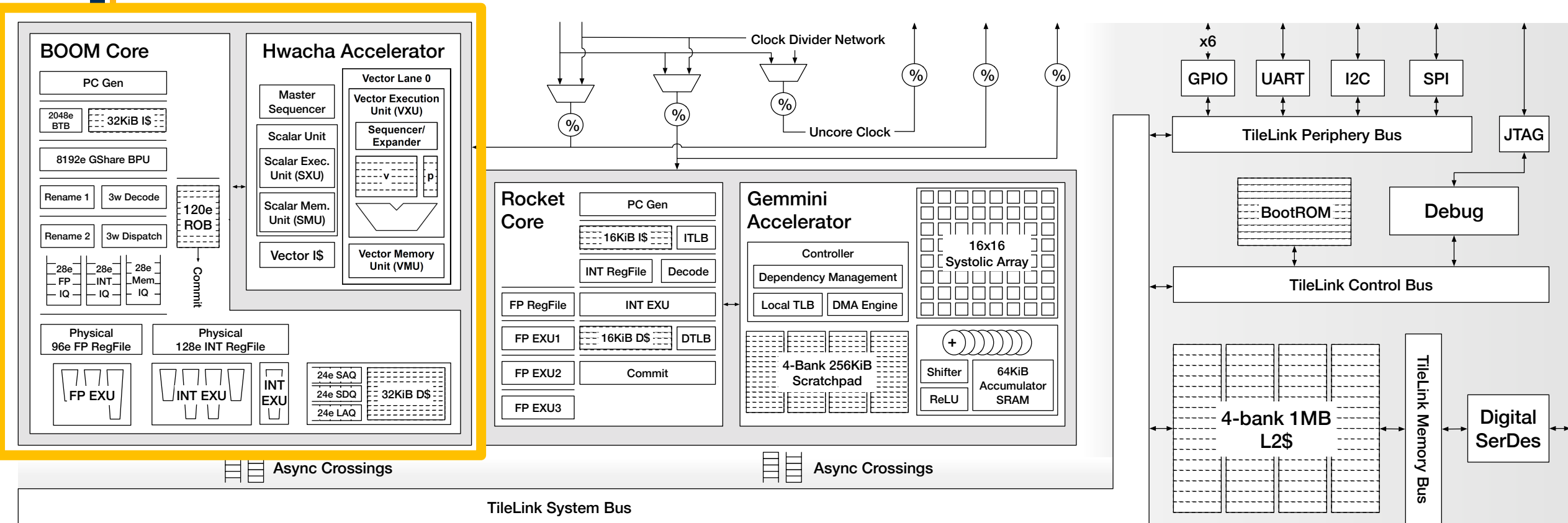

- Updated BOOMv2.2 - RVC, RoCC accel. support, Non-speculative mode
- Hwacha Vector Accelerator



Machine Learning Domain

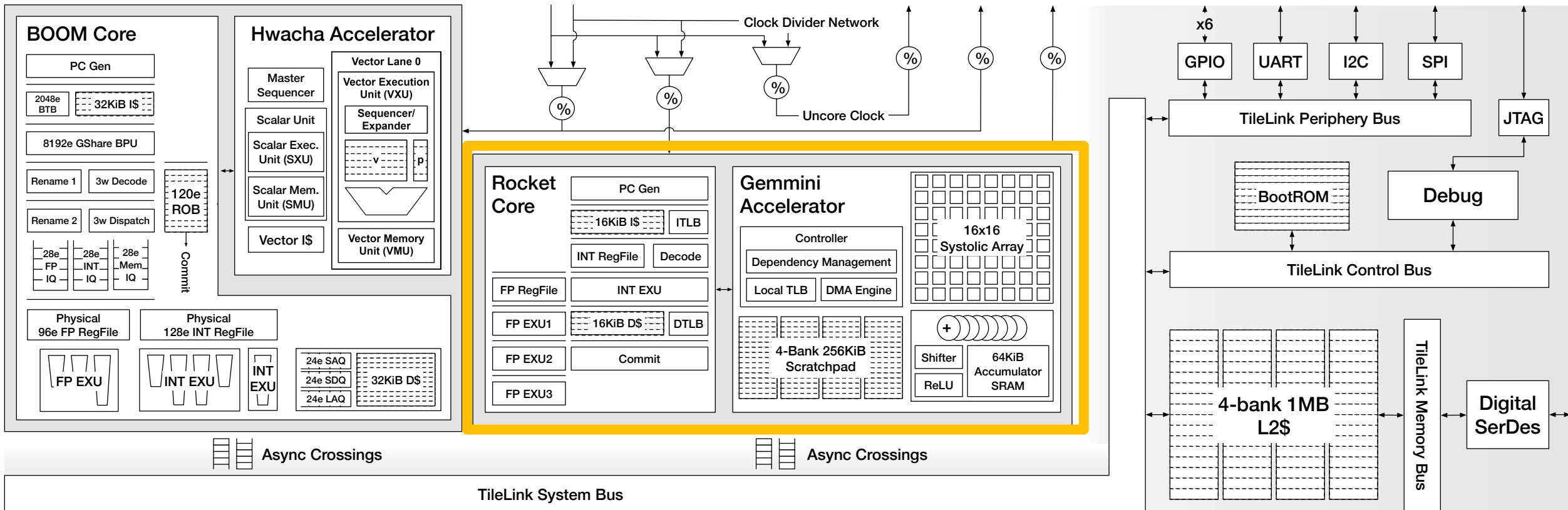

- Rocket In-Order Core
- Gemmini DNN Accelerator



Uncore Domain

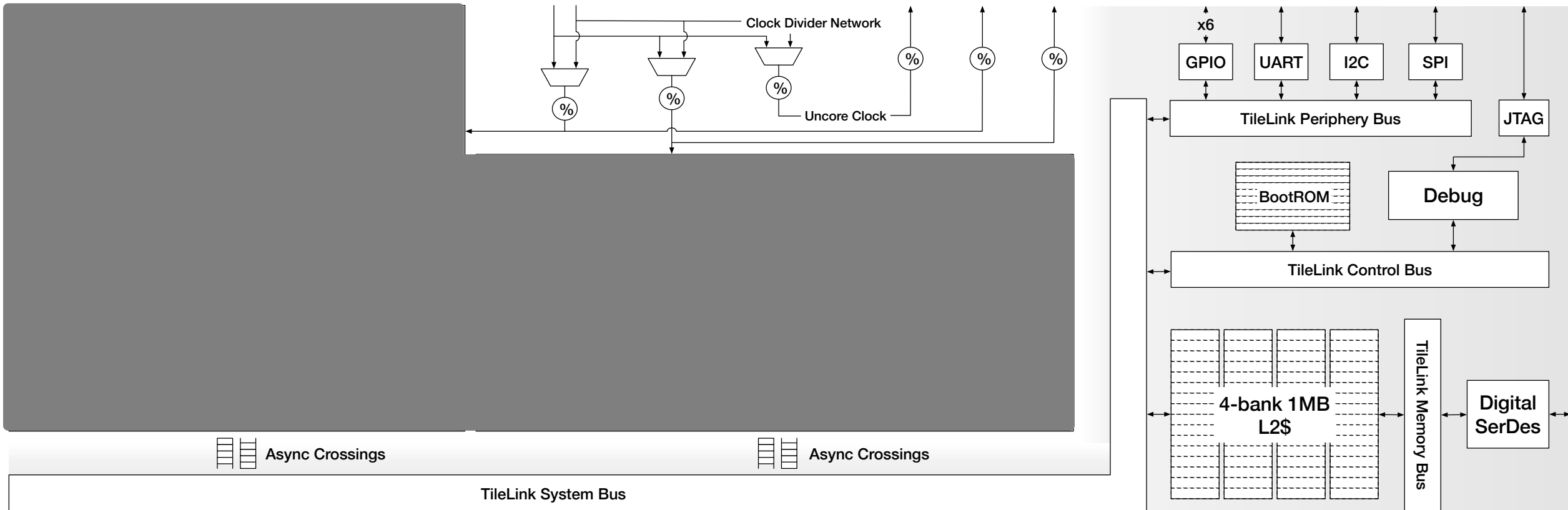

- Shared 1MB L2
- Configurable clock div./muxes
- GPIO, UART, SPI, I2C, JTAG
- Low-speed SerDes



GDS Photo

4mm x 4mm

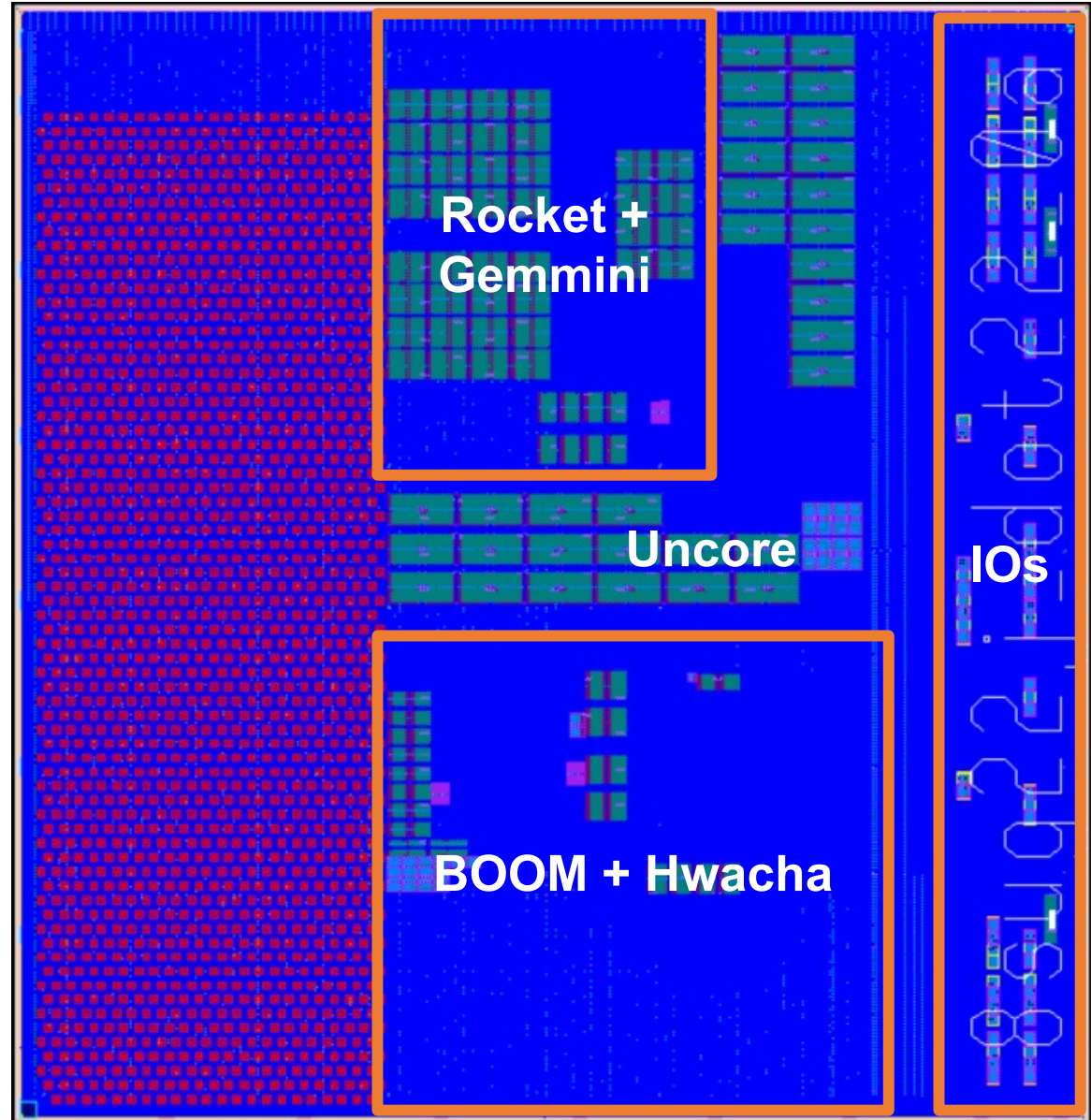

~2.5mm



Runs Linux + More!

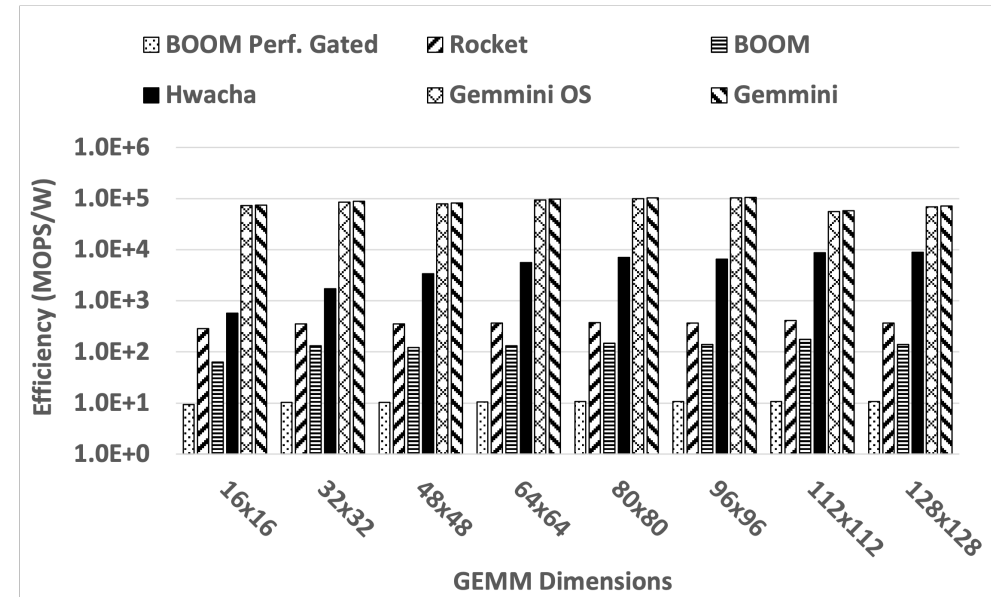
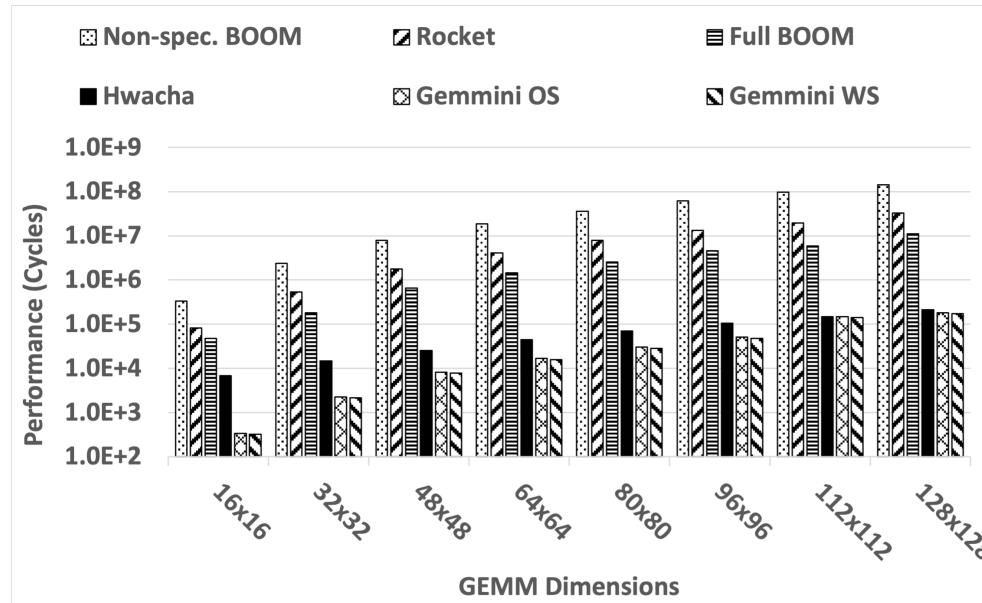

Core Type		CoreMark		Dhrystone	
		Raw	CoreMark/MHz	Dhrystone/S	DMIPS/MHz
Rocket		1185	2.11	1883.54	1.07
BOOM	Non-Speculative	45.09	0.27	301.29	0.17
	Full/Normal	395.79	2.37	3750.93	2.13



Takeaways

- Published at ESSCIRC 2021:
 - A 16mm² 106.1 GOPS/W Heterogeneous RISC-V Multi-Core Multi-Accelerator SoC in Low-Power 22nm FinFET
- Developed in parallel with 1st Chipyard framework
 - 2nd BOOM tapeout – with new BOOM and new people!
 - Added Hwacha, Gemmini, and open-source L2!
 - Demonstrates booting real workloads!
- Giving back to future chips
 - Added a bringup flow to Chipyard
 - Added a lot of test-chip test features into Chipyard
 - Added an FPGA prototyping flow





Takeaways

- Published at ESSCIRC 2021:
 - A 16mm² 106.1 GOPS/W Heterogeneous RISC-V Multi-Core Multi-Accelerator SoC in Low-Power 22nm FinFET
- Developed in parallel with 1st Chipyard framework
 - 2nd BOOM tapeout – with new BOOM and new people!
 - Added Hwacha, Gemmini, and open-source L2!
 - Demonstrates booting real workloads!
- Giving back to future chips
 - Added a bringup flow to Chipyard
 - Added a lot of test-chip test features into Chipyard
 - Added an FPGA prototyping flow

